

TEMPLATE HINGES

FULL MORTISE – SWING CLEAR – STANDARD WEIGHT
 SIZE 4.5 INCHES
 (045)

DRAWING NOT TO SCALE

Bommer Industries Inc.
 19810 Highway 176
 P.O. Box 187
 Landrum SC 29356

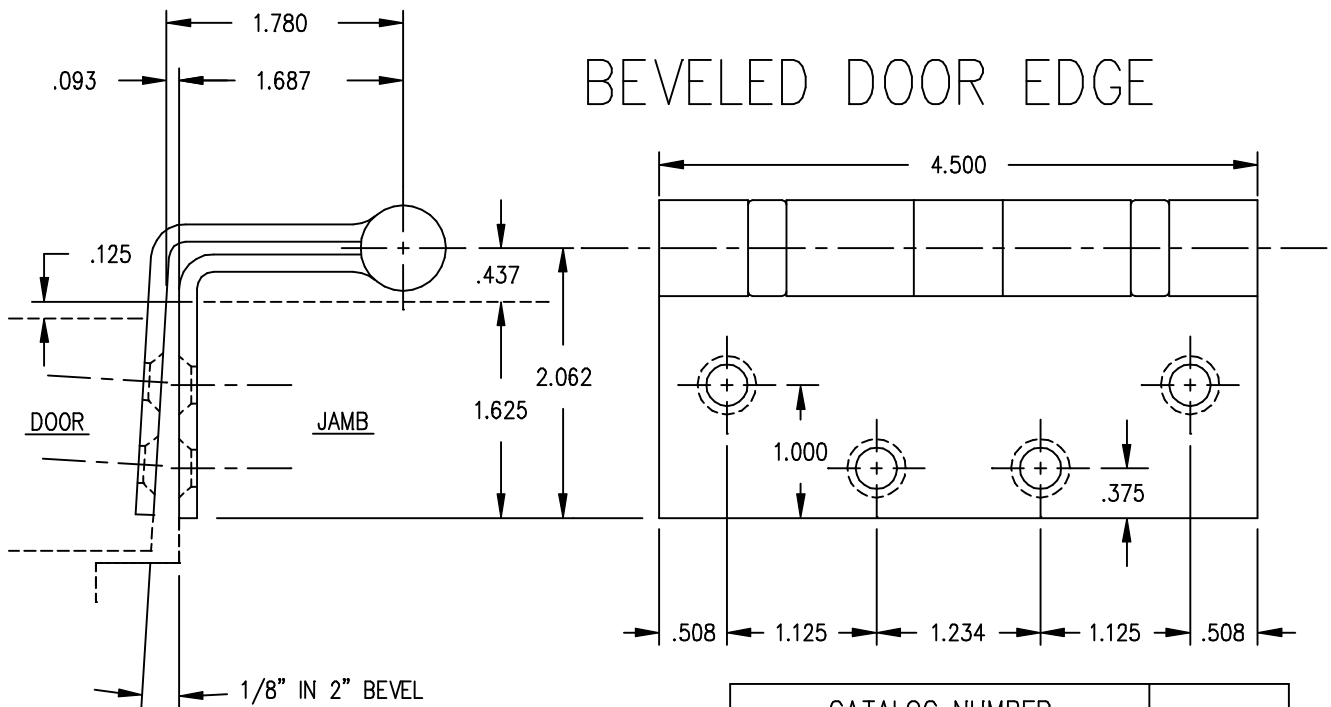
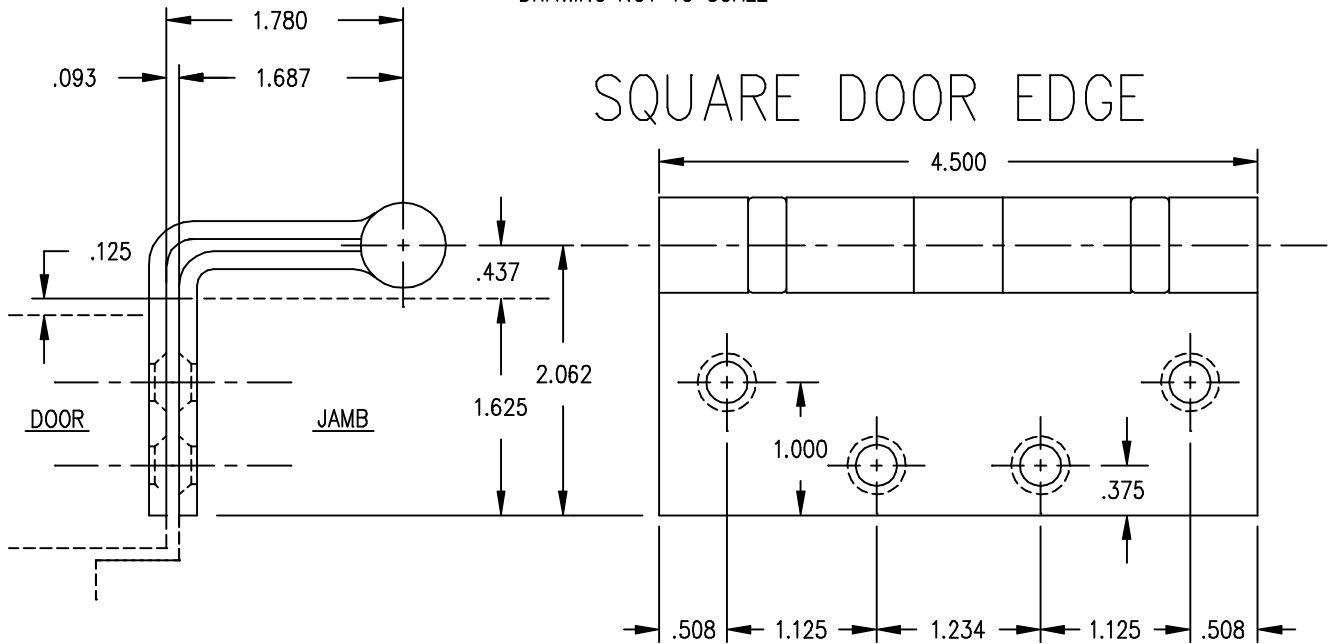

MACHINE SCREW SIZE – 12-24 F.H.
 WOOD SCREW SIZE – 1 1/4 NO.12 F.H.

CATALOG NUMBER			GUAGE OF METAL
STEEL HINGES	BRASS OR BRONZE HINGES	STAINLESS STEEL HINGES	
BB5020	BB5021	BB5022	.134
LB8020	LB8021	LB8022	.134