

Bommer Industries Inc.
19810 Asheville Highway
P.O. Box 187
Landrum SC 29356

DOOR AND FRAME PREPARATION TEMPLATE

LB8000 SERIES CONCEALED ELECTRIC MONITOR HINGES

5 INCH FULL MORTISE, 3-KNUCKLE, LUBE BEARING, STANDARD AND HEAVY WEIGHT.

DRAWING NOT TO SCALE

HINGES ARE NON-LOAD
BEARING AND MUST BE
MOUNTED IN THE CENTER
POSITION ONLY.

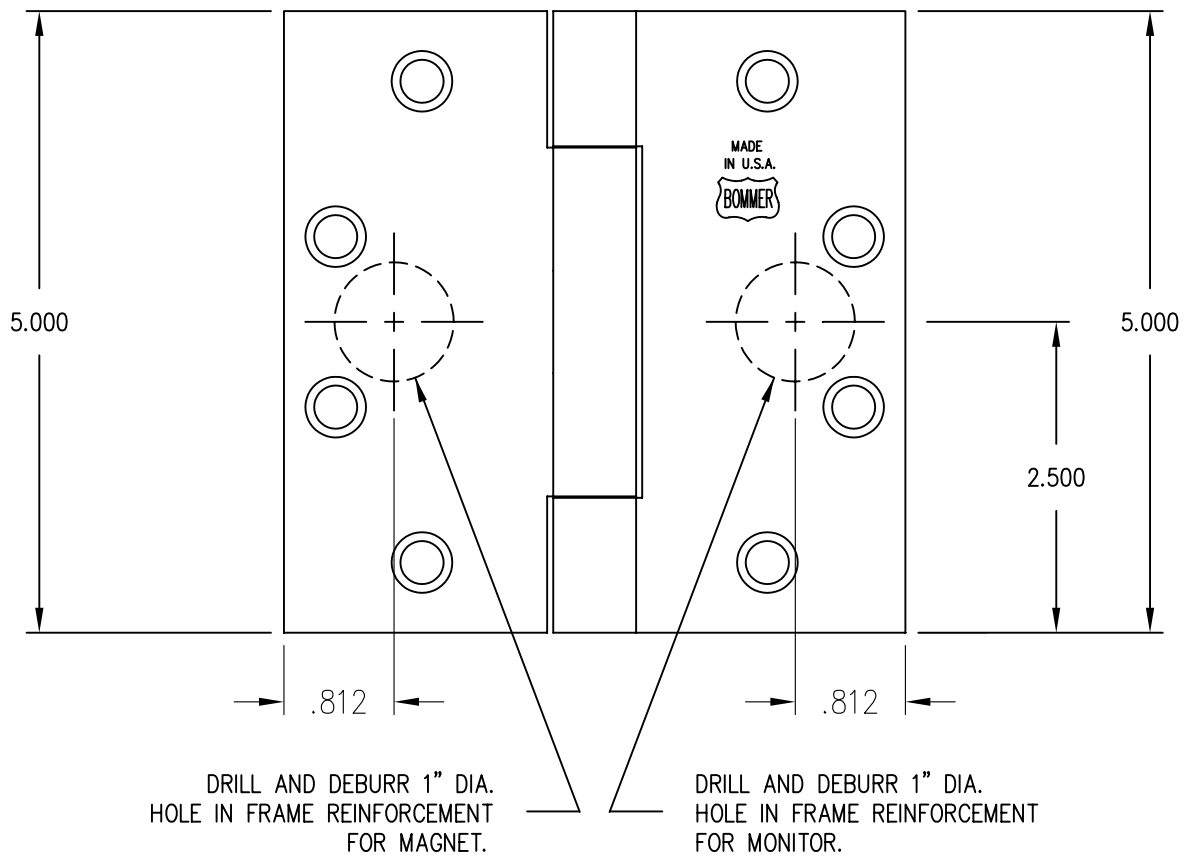

NOTE:

FOR MOUNTING HOLE DIMENSIONS
REFER TO TEMPLATE NOS.

8000-500-T FOR STANDARD WEIGHT

LB8004-500-T FOR HEAVY WEIGHT

TEMPLATE NO. LB8060-500EM-T